

Drill Stands KF 160

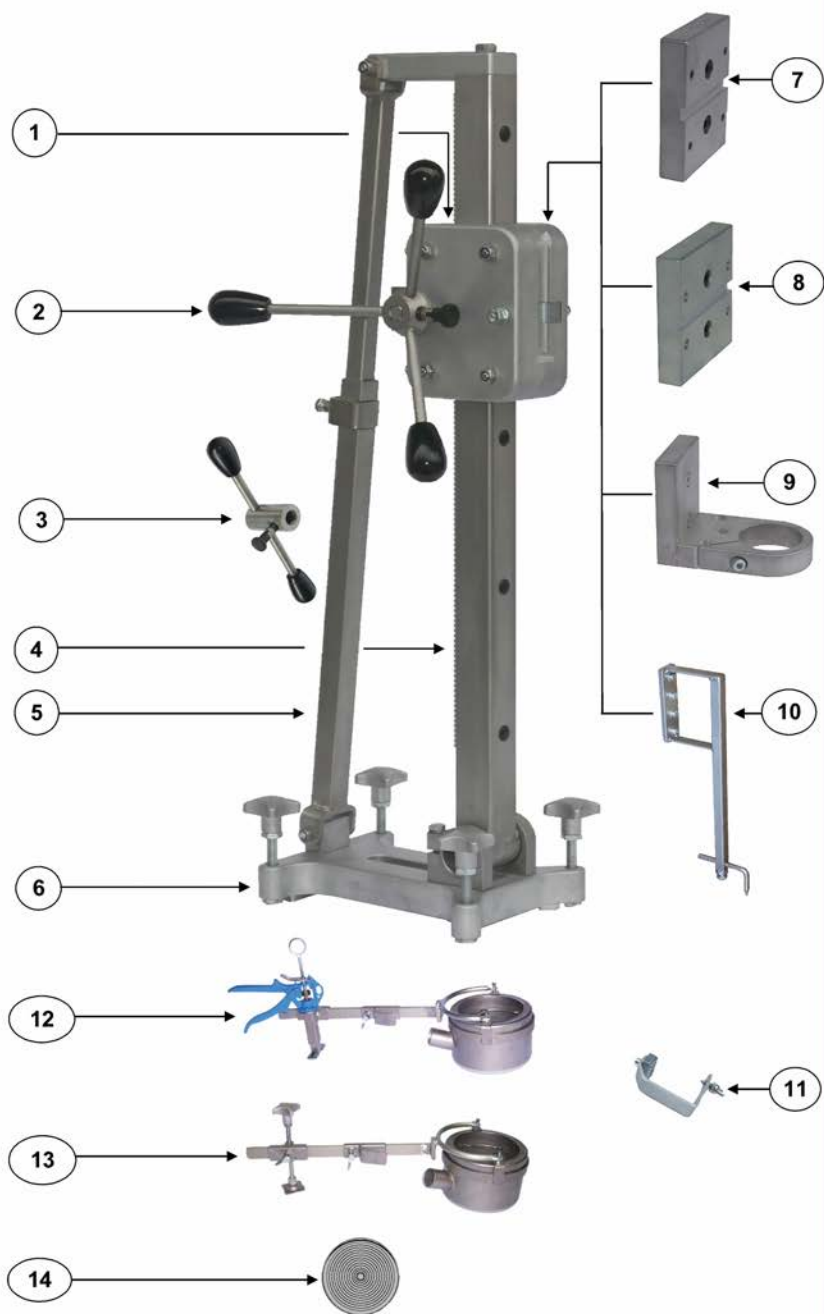

components and parts list KF 160

Item	Designation	Order no.	Piece	Price/Pice
1	Carriage cpl.	160.1.00 K	1	
2	Crank cpl.	160.2.00 K	1	
3	Single lever crank cpl.	160.3.00 K	1	
4	Column cpl.	160.4.00 K	1	
5	Support cpl.	160.5.00 K	1	
6	Foot plate steel cpl.	160.6.00 K	1	
7	Drilling motor plate 80 cpl.	160.7.00 K	1	
8	Drilling motor plate 100 cpl.	160.8.00 K	1	
9	Instep neck adapter cpl.	160.9.00 K	1	
10	Drilling middles indicator cpl.	160.10.00 K	1	
11	End stop cpl.	160.11.00 K	1	
12	Drill water suction ring + chuck handle 130	160.12.00 K	1	
13	Drill water suction ring + chuck screw 130	160.13.00 K	1	
14	Membrane	160.14.00 K	1	

Technical Specifications KF 160:

Max. drilling diameter	10-160 mm
Carriage feed path	520 mm
Weight with clamp	11,5 kg
Total height mm	800
Motor power max.	2,3 KW
Speed gearboxes	1:14

For more information, please visit: www.flei-ka.de

Please visit us at: www.facebook.com/fleikasoyen